

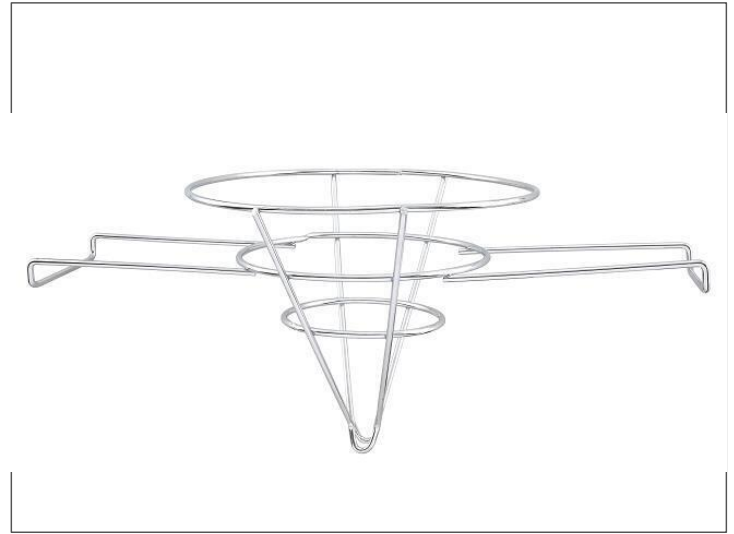

WINCO INDUSTRIE

012153 - Rack Grease Filter Cone Ff 10

Good Quality

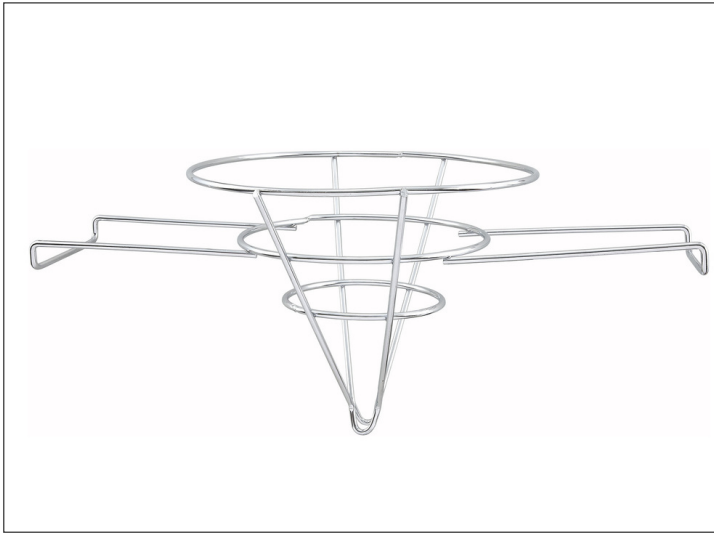

Long Description

Fryer Filter Stand, Chrome Plated

Benefits

Good Quality

Storage & Usage

Dry Warehouse

Product Specifications

Brand	Manufacturer	Product Category
WINCO INDUSTRIE	D. W. L. Int'L Trading Inc.	

MFG #	SPC #	GTIN	Pack	Pack Desc.
FF-10	012153	00842169111889	1	1 / ea

Gross Weight	Net Weight	Catch Weight	Country of Origin	Kosher	Child Nutrition
1lb	1lb	No	CHN		No

Shipping Information						
Length	Width	Height	Volume	TlxHI	Shelf Life	Storage Temp From/To
17.88in	9.38in	7.63in	0.74ft3	1x1	1825DAYS	15°F / 120°F